

iBend

PRESS BRAKE



LeMans

Shaping the Future

VALUES

Experience in machine manufacturing "Since 1950"
High quality awareness After sale services assurance
Corporate approach Dedication to customersatisfaction

LeMans

VISION

Providing technological solutions to sheet metal industry through research & development activities and aim to become world's leading brand by continuous growth.

LeMans PRESS BRAKE



HYDRAULIC PRESS BRAKE

Quality and service support is accepted as principle. Designing and Manufacturing are based on reliability, durability and precision. Machines are easy to use and are built to be ready for user errors. Machines are designed and analyzed with 3-D computer programs, manufactured as welded steel construction, "stress relieved", precisely machined in moving column CNC machining centres, equipped with world-known equipments and presented to the customers use after quality control.



A Series

LeMans

A Series

Standard Features

1. Y2, X CNC 3 Axes
2. 210mm Stroke, 410mm Throat Depth
3. ESAS530 CNC Control Unit
4. ±0,03 accuracy A/C motorized with inverter, back gauge.
5. Manual Promecam punch tool holder
6. LeMans special narrow bottom table (European type)
7. Standard punch tools (H: 67, 85°, R:08)
8. Standard die tools (60x60mm, 4 Vee V=16-22-35-50mm, 85°, H:60)
9. High quality and precision linear scales
10. LED illumination on RAM

Optional Features

1. R axis back gauge
2. Sliding front sheet support arms
3. Wide bottom table for Multi Vee dies.
4. Anti-deflection crowning with original Wila wedges
5. AKAS or DSP front laser safety systems
6. Additional back gauge fingers
7. Front laser safety

ESA S530
CNC Control Unit
7" Color
2D Graphic Screen

MORE CNC CONTROLLER RECOMMENDATIONS

• ESA S630



10" Touch
2D Graphic Screen
With Offline PC Software

- ESA 640 - Standard 15", 2D
- ESA 650 - 15", 2D

• DELEM DA-53T



10" Touch
2D Numerical Screen
With Offline PC Software

- DELEM DA-58T - 15", 2D
- DELEM DA-66T - 17", 2D

• CYBELEC CybT8 PS



7" Touch
2D Graphic Screen
With Offline PC Software

- CYBELEC CybT12 - 12", 2D
- CYBELEC CybT15 - 15", 2D



Standard

X axis back gauge



Standard

Magnetic linear scales
(0,005mm precision)



Standard

Manual Promecam
Punch tool holder

Throat
410 mm

Stroke
210 mm

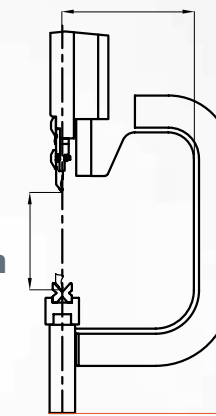

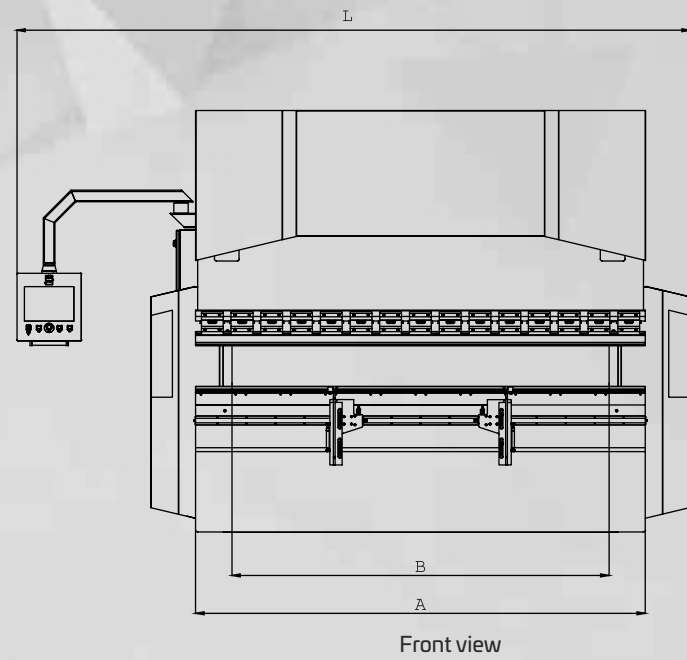

Front view

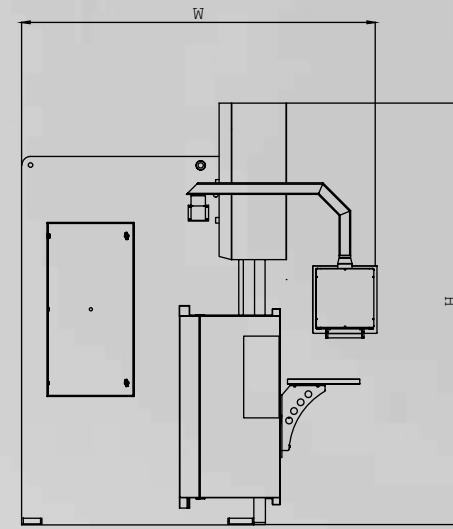

Side view

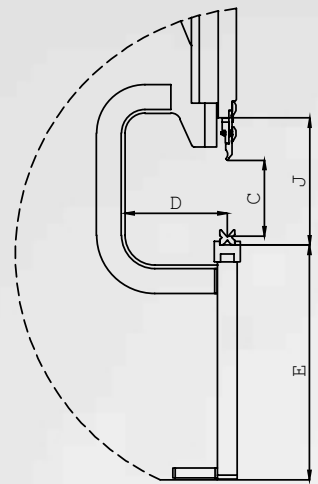

Work zone detail

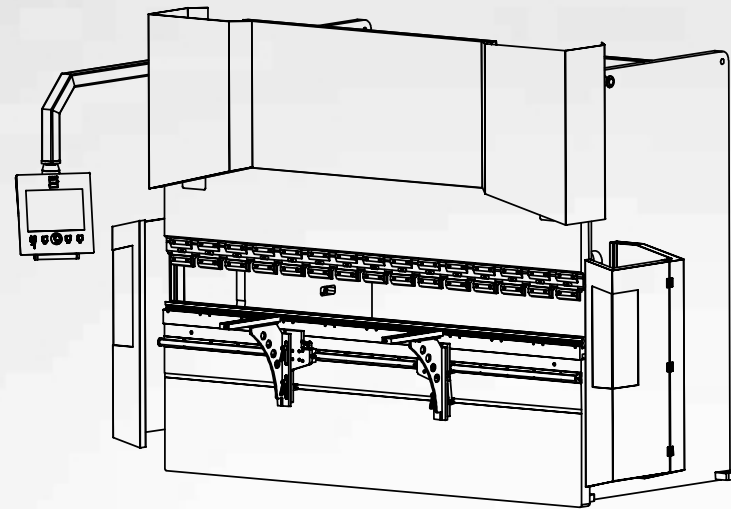

Perspective view

A-Series - Technical Specifications

A Bending Force	Bending Length	Distance between columns	Stroke	Daylight	Throat	Table Height	Machine Dimensions			Speed			Oil tank	Weight	Main motor
	A	B	C	J	D	E	Length x Width x Height (L x W x H)			Approach Speed	Return Speed	Bending Speed	Lt	kg	kW
	mm	mm	mm	mm	mm	mm	mm			mm/s	mm/s	mm/s			
A40	1250	1100	210	465	410	885	3060	2195	2730	150	120	10	95	3400	4
A60	2100	1600	210	465	410	870	3660	2175	2820	160	135	10	170	4290	5,5
	2600	2150	210	465	410	870	4210	2175	2820	160	135	10	170	4790	5,5
A100	2600	2150	210	465	410	905	4220	2230	2855	200	135	10	170	6150	7,5
	3100	2600	210	465	410	905	4670	2230	2855	200	135	10	180	6650	7,5
A135	3100	2600	210	465	410	905	4690	2340	2795	210	130	10	180	7200	11
	3700	3200	210	465	410	905	5290	2340	2850	210	130	10	180	9200	11
A175	4100	3600	210	465	410	905	5590	2440	2950	210	130	10	180	9750	11
	3100	2600	210	465	410	945	4705	2430	2840	180	130	10	180	8400	15
A220	3700	3200	210	465	410	945	5305	2430	2840	180	130	10	180	9800	15
	4100	3600	210	465	410	945	5600	2530	2950	180	130	10	180	10250	15
A220	3100	2600	210	465	410	880	4720	2415	2805	180	140	10	290	10000	18,5
	3700	3200	210	465	410	930	5320	2415	2805	180	140	10	290	11400	18,5
	4100	3600	210	465	410	930	5620	2515	2905	180	140	10	290	11800	18,5

*For dimension details please look at left page.

**Technical specifications may change without advance notice

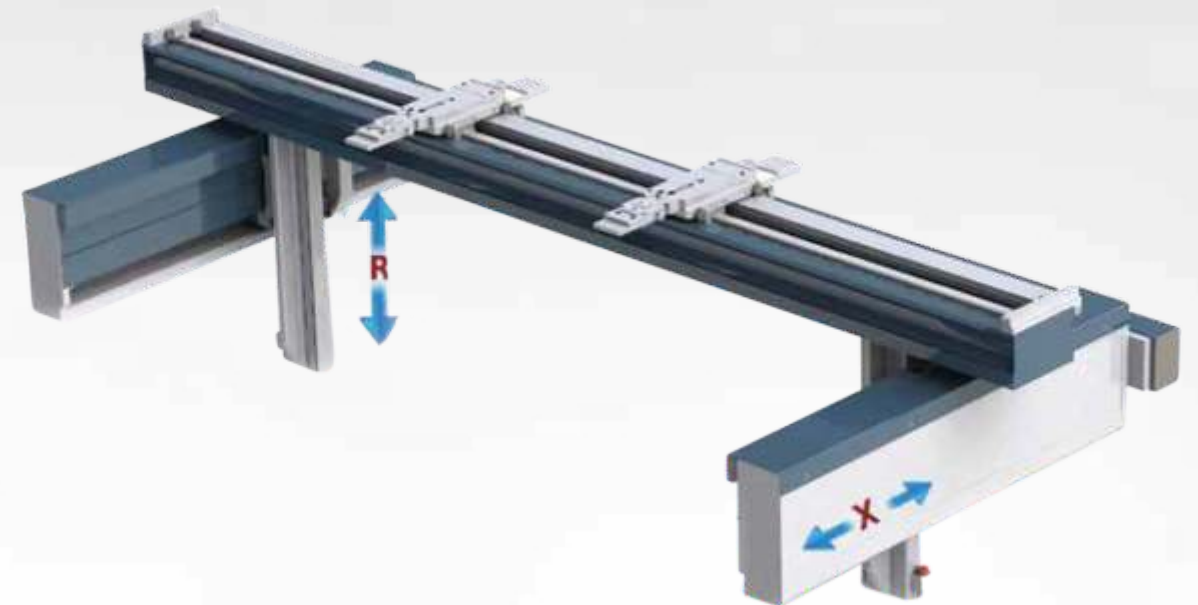

B Series

LeMans

B Series

Standard Features

1. Y1,Y2,X CNC 3 Axes
2. 260mm Stroke, 410mm Throat Depth
3. ESAS630 CNC Control Unit
4. ±0,03 accuracy SERVO motorized back gauge X=750mm
5. Quick clamp Promecam punch tool holder
6. Sliding front sheet support arms
7. LeMans special narrow bottom table (European type)
8. GIVI optic linear scales
9. Standard punch tools (H: 67, 85°, R:08)
10. Standard die tools (60x60mm, 4 Vee V=16-22-35-50mm, 85°, H:60)
11. LED illumination on RAM

Optional Features

1. X to 2-4-6-8 axis back gauge options
2. Wide bottom table for Multi Vee dies.
3. Anti-deflection crowning with original Wila wedges
4. AKAS or DSP front laser safety systems
5. Additional back gauge fingers
6. Front laser safety

ESA S630
CNC Control Unit
10" Color
2D Graphic Screen

MORE CNC CONTROLLER RECOMMENDATIONS

• ESA S640



15" Touch
2D Graphic Screen
With Offline PC
Software

- ESA 650 - 15", 2D
- ESA 660W - 19, 3D *.dxf

• DELEM DA-53T



15" Multi Touch Color
2D Graphic Screen
With Offline PC
Software

- DELEM DA-53T - 10", numeric
- DELEM DA-66T - 17", 2D

• CYBELEC CybT12 PS



12" Touch
2D Graphic Screen
With Offline PC
Software

- CYBELEC CybT8 - 7", 2D
- CYBELEC CybT15 - 15", 2D

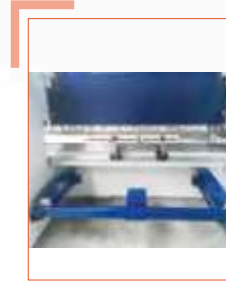

Standard

Front sheet support arms



Standard

Optic linear scales
(0,005mm precision)



Standard

Quick clamp Promecam
Punch tool holder

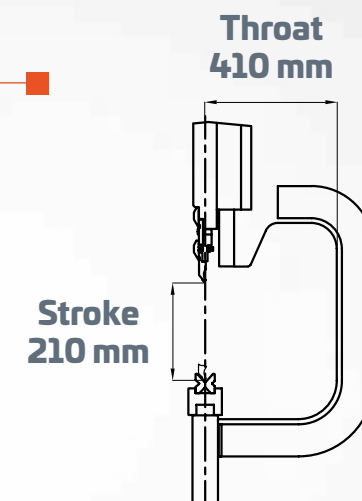

B-Series - Technical Specifications

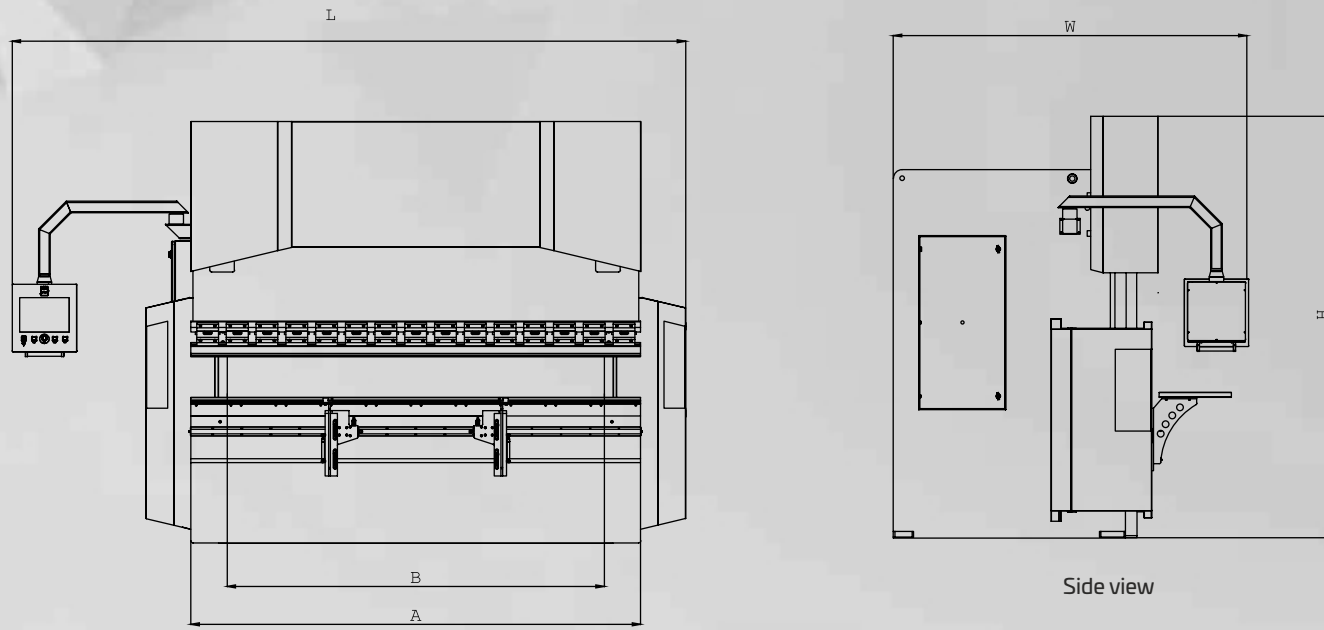

Front view

Side view

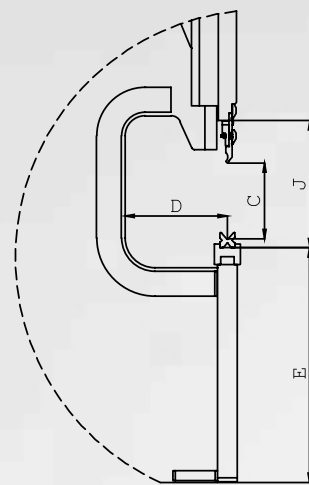

Work zone detail

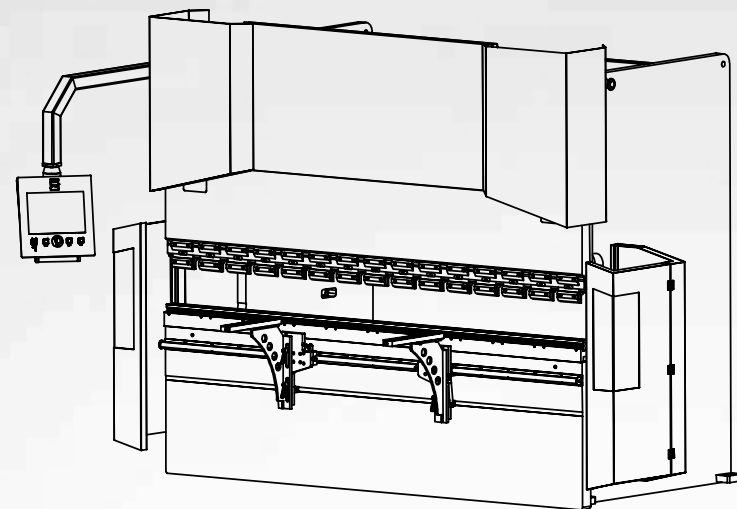

Perspective view

B Bending Force	Bend - ing Length	Distance between columns	Stroke	Daylight	Throat	Table Height	Machine Dimensions			Speed			Oil tank	Weight	Main motor
	A	B	C	J	D	E	Length x Width x Height (L x W x H)			Ap- proach Speed	Return Speed	Bending Speed	Lt	kg	kW
	mm	mm	mm	mm	mm	mm	mm			mm/s	mm/s	mm/s			
B40	1250	1100	260	465	410	880	3060	2080	2820	150	120	10	95	3500	4
B60	2100	1600	260	465	410	870	3660	2175	2905	160	135	10	170	4560	5,5
	2600	2150	260	465	410	890	4210	2175	2905	160	135	10	170	5010	5,5
B100	2600	2150	260	465	410	885	4220	2230	2950	200	135	10	170	6430	7,5
	3100	2600	260	465	410	905	4670	2230	2950	200	135	10	180	6780	7,5
B135	3100	2600	260	465	410	940	4690	2340	2980	210	130	10	180	7750	11
	4100	3600	260	465	410	955	5590	2440	2990	210	130	10	180	10000	11
B175	3100	2600	260	465	410	955	4700	2430	2975	180	130	10	180	8850	15
	3700	3200	260	465	410	955	5300	2430	2990	180	130	10	180	10500	15
	4100	3600	260	465	410	955	5600	2530	2980	180	130	10	180	11050	15
B220	3100	2600	260	465	410	955	4720	2430	2998	180	140	10	290	10400	18,5
	3700	3200	260	465	410	970	5320	2430	3045	180	140	10	290	11950	18,5
	4100	3600	260	465	410	970	5620	2530	3035	180	140	10	290	12750	18,5
B270	3100	2600	260	465	410	960	4840	2500	3040	150	120	10	290	12300	22
	3700	3200	260	465	410	960	5440	2500	3040	150	120	10	290	13500	22
	4100	3600	260	465	410	960	5640	2500	3040	150	120	10	290	14300	22
B320	3100	2600	260	485	410	955	4860	2490	3080	150	110	10	290	13700	22
	3700	3200	260	485	410	955	5460	2490	3085	150	110	10	290	14500	22
	4100	3600	260	485	410	955	5660	2490	3085	150	110	10	290	15300	22
	5100	4200	260	485	410	1030	6660	2570	3210	150	110	10	290	20500	22
	6100	5100	260	485	410	1060	7560	2570	3440	150	110	10	290	25000	22

*For dimension details please look at left page.

**Technical specifications may change without advance notice

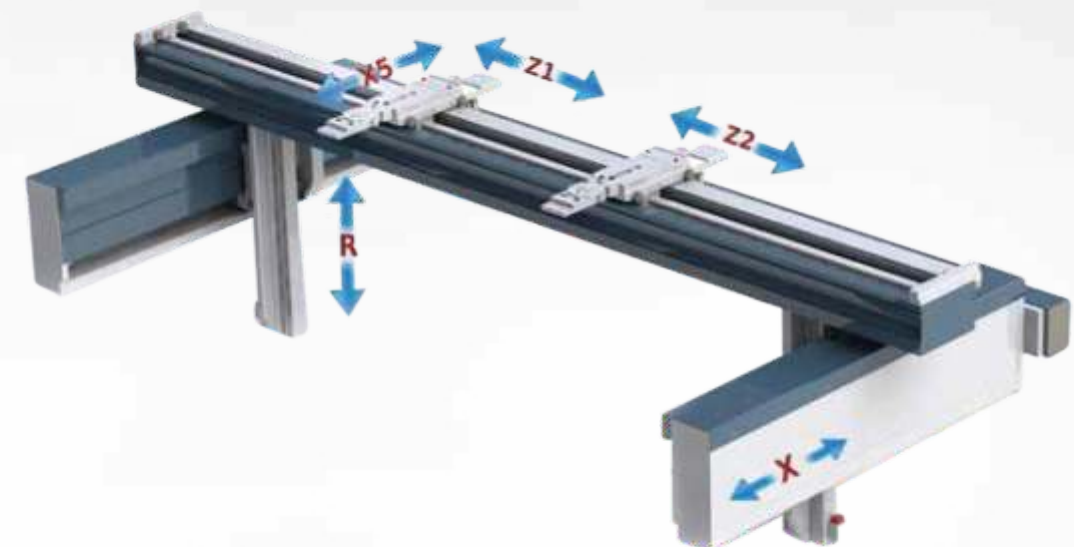

C Series



ESA S640
CNC Control Unit
15" Touch
2D Graphic Screen



Standard Features

1. Y1,Y2,X,R CNC 4 Axes
2. 310mm Stroke, 410mm Throat Depth
3. ESAS640 CNC Control Unit
4. $\pm 0,03$ accuracy SERVO motorized back gauge.
X=750mm,
R=250mm
5. Quick clamp Promecam punch tool holder
6. Sliding front sheet support arms
7. Manuel Anti-deflection crowning with original Wila wedges.
8. MVD special narrow bottom table (European type)
9. GIVI optic linear scales
10. Standard punch tools (H: 67, 85°, R:08)
11. Standard die tools (60x60mm, 4 Vee V=16-22-35-50mm, 85°, H:60)
12. LED illumination on RAM

Optional Features

1. X+R to 4-6-8 axis back gauge options
2. Roller Rol200 hydraulic punch clamping
3. Wila hydraulic punch clamping
4. Wide bottom table for Multi Vee dies.
5. Motorized Anti-deflection crowning with original Wila wedges
6. 1.000mm X axis travel
7. AKAS or DSP front laser safety systems
8. Additional back gauge fingers
9. Front laser safety

MORE CNC CONTROLLER RECOMMENDATIONS

- ESA S650

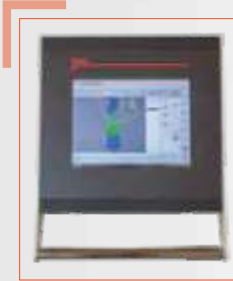

15" Touch
2D Graphic Screen
With Offline PC
Software

- ESA 660W - 19, 3D *.dxf

- DELEM DA-66T

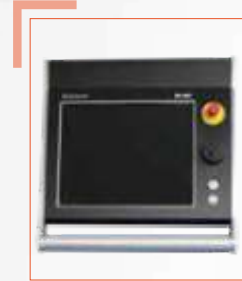

17" Multi Touch Color
2D Graphic Screen
With Offline PC
Software

- DELEM DA-69T - 17", 3D *.dxf

- CYBELEC CybT15 PS



15" Touch
2D Graphic Screen
With Offline PC
Software

- CYBELEC CybT12 - 12", 2D



Standard
X+R Axes Back Gauge



Standard
Manual Crowning
(original WILA Wedges)

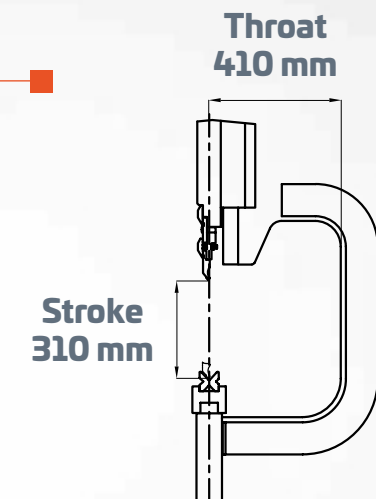

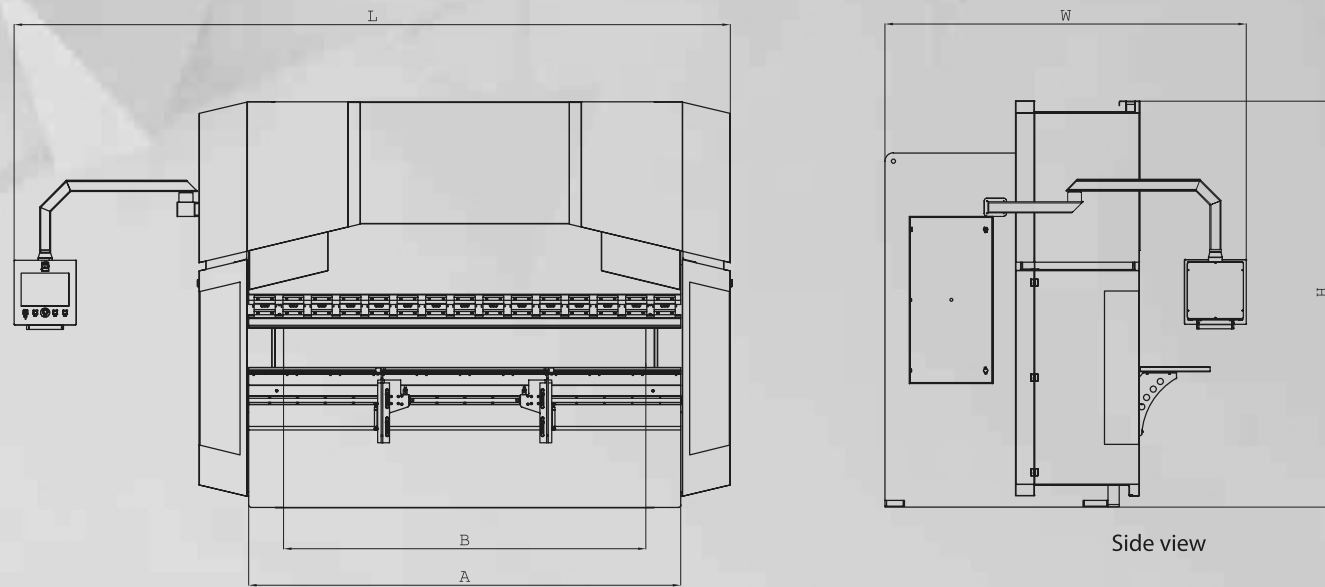

Front view

Side view

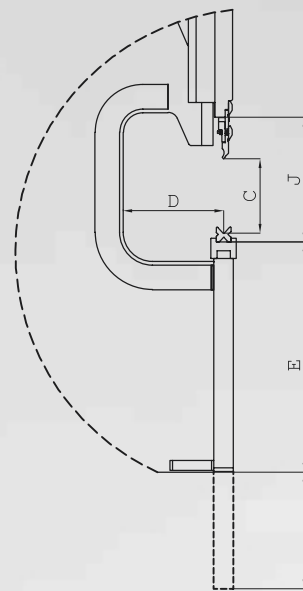

Work zone detail

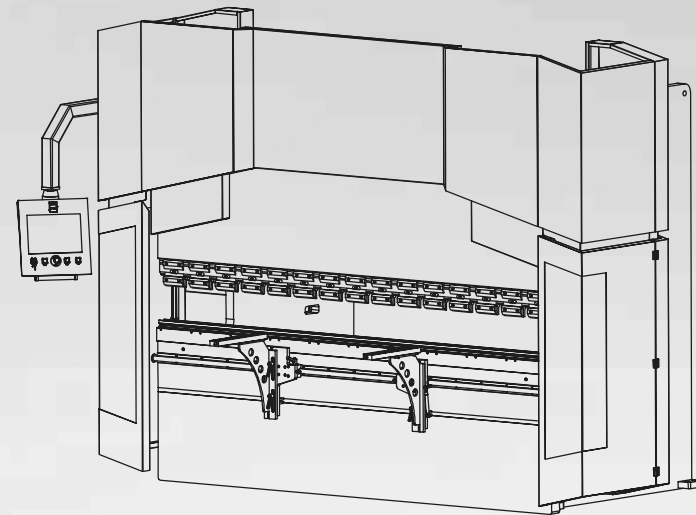

Perspective view

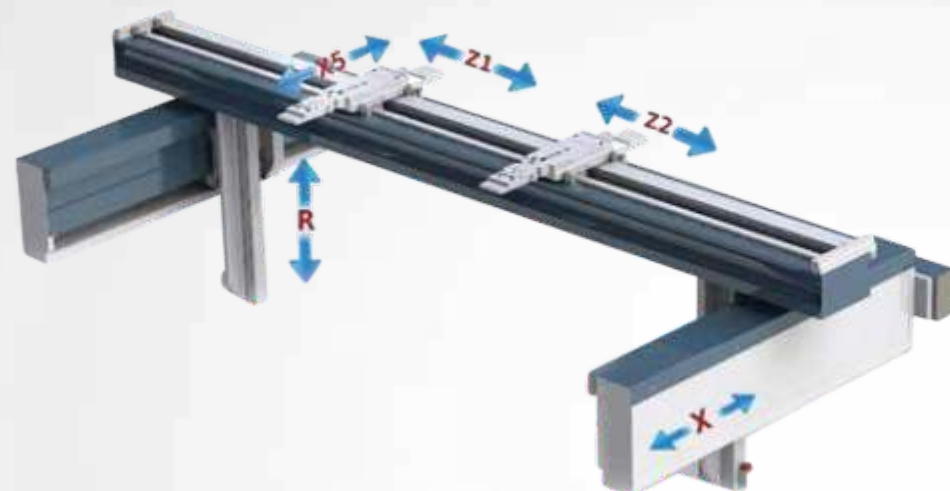

C-Series - Technical Specifications

C Bending Force	Bending Length	Distance between columns	Stroke	Daylight	Throat	Table Height	Machine Dimensions			Speed			Oil tank	Weight	Main motor
	A	B	C	J	D	E	Length x Width x Height (L x W x H)			Approach Speed	Return Speed	Bending Speed	Lt	kg	kW
	mm	mm	mm	mm	mm	mm	mm			mm/s	mm/s	mm/s			
C100	2600	2150	310	515	410	890	4220	2230	2950	200	135	10	180	6950	7,5
	3100	2600	310	515	410	905	4670	2230	2950	200	135	10	180	7300	7,5
C135	3100	2600	310	515	410	935	5150	2650	2950	210	130	10	180	8350	11
	4100	3600	310	515	410	945	6150	2650	2995	210	130	10	180	10600	11
C175	3100	2600	310	515	410	935	5150	2650	2950	180	130	10	180	9700	15
	3700	3200	310	515	410	945	5750	2650	2950	180	130	10	180	11350	15
C220	3100	2600	310	515	410	940	5180	2650	2950	180	140	10	290	11300	18,5
	3700	3200	310	515	410	965	5780	2650	3040	180	140	10	290	12850	18,5
	4100	3600	310	515	410	965	6180	2650	3040	180	140	10	290	13650	18,5
	5100	4200	310	515	410	995	7180	2650	3090	180	140	10	290	17000	18,5
	6100	5100	310	515	410	995	8180	2650	3090	180	140	10	290	21700	18,5
C270	3100	2600	310	515	410	950	5200	2650	3040	150	120	10	290	13300	22
	3700	3200	310	515	410	955	5800	2650	3040	150	120	10	290	14500	22
C320	3100	2600	310	535	410	955	5300	2655	3070	150	110	10	290	14700	22
	3700	3200	310	535	410	955	5750	2655	3080	150	110	10	290	15500	22
	4100	3600	310	535	410	955	6150	2655	3130	150	110	10	290	16800	22
	5100	4200	310	535	410	1045	7150	2655	3140	150	110	10	290	21500	22
	6100	5100	310	535	410	1065	8150	2655	3170	150	110	10	290	26000	22
C400	3100	2600	310	535	410	1015	5150	2685	3400	100	80	8	400	18700	30
	3700	3200	310	535	410	975	5750	2685	3400	100	80	8	400	20700	30
	4100	3600	310	535	410	985	6150	2700	3400	100	80	8	400	22500	30
	5100	4200	310	535	410	980	7150	2700	3400	100	80	8	400	25500	30
	6100	5100	310	535	410	1055	8150	2700	3600	100	80	8	400	33000	30
C500	8100	7100	310	535	410	815	10150	2785	3750	100	80	8	400	45000	30
	3700	3200	310	535	410	1035	5750	2735	3400	80	70	8	500	24100	37
	4100	3600	310	535	410	1025	6150	2740	3400	80	70	8	500	26300	37
	5100	4200	310	535	410	1055	7150	2750	3650	80	70	8	500	30000	37
	6100	5100	310	535	410	965	8200	2750	3900	80	70	8	500	39500	37
	8100	7100	310	535	410	750	10200	2750	4000	80	70	8	500	55500	37

*For dimension details please look at left page.
 **Technical specifications may change without advance notice.

D Series



ESA S650
CNC Control Unit
15" Color Touch
2D Graphic Screen
With Offline PC Software



Standard Features

1. V1,Y2,X,R CNC 4 Axes (X + R Servo)
2. **410mm Stroke, 510mm Throat Depth**
3. **ESAS650** CNC Control Unit
4. $\pm 0,03$ accuracy SERVO motorized back gauge.
X=750mm, R=250mm
5. Quick clamp Promecam punch tool holder
6. **Sliding front sheet support arms with hand Wheel**
7. **Motorized Anti-deflection crowning** with original Wila wedges.
8. LeMans special narrow bottom table (European type)
9. GIVI optic linear scales
10. Standard punch tools (H: 67, 85°, R:08)
11. Standard die tools (60x60mm, 4 Vee
V=16-22-35-50mm, 85°, H:60)
12. LED illumination on RAM

Optional Features

1. X + R to 4-6-8 axis back gauge options
2. Roller Rol200 hydraulic punch clamping
3. Wila hydraulic punch clamping
4. Wide bottom table for Multi Vee dies.
5. 1.000mm X axis travel
6. AKAS or DSP front laser safety systems
7. Additional back gauge fingers
8. Front laser safety

MORE CNC CONTROLLER RECOMMENDATIONS

• ESA S660W



19" Touch
3D Graphic Screen
*.dxf import/export
With Offline PC
Software

- ESA 675W - 21", 3D *.dxf

• DELEM DA-69T



17" Multi Touch Color
3D Graphic Screen
*.dxf import/export
With 3D Offline PC
Software

- DELEM DA-58T - 15", 2D
- DELEM DA-66T - 17", 2D

• CYBELEC Visitouch 19MX



19" Touch
3D Graphic Screen
*.dxf import/export
With Offline PC
Software

- CYBELEC CytT15PS - 15", 2D



Standard

Motorized Crowning
(original WILA Wedges)

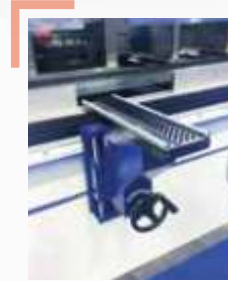

Standard

Sliding front support arms
With hand wheel adjustment

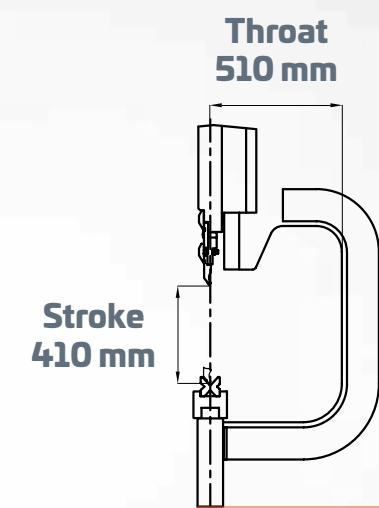

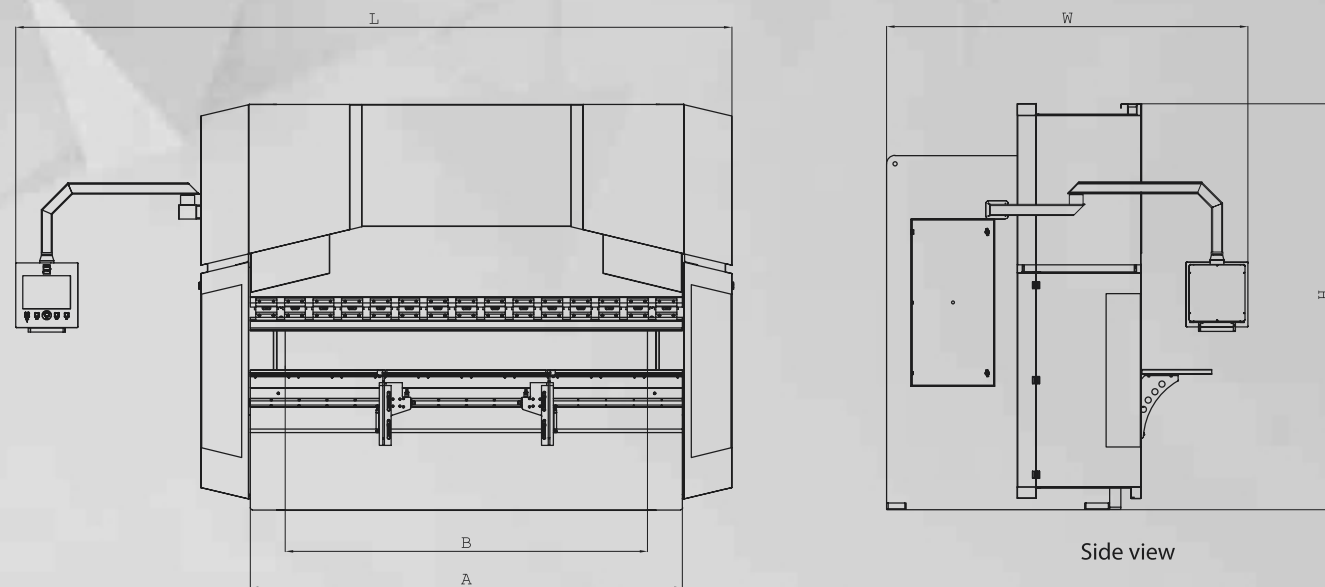

Front view

Side view

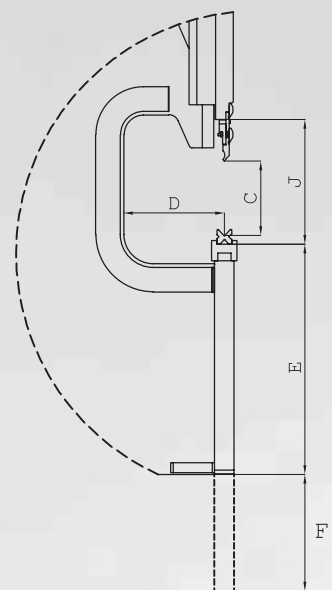

Work zone detail

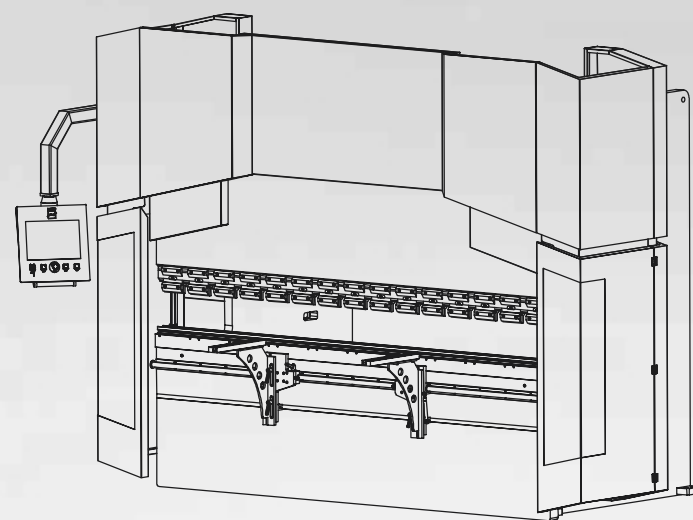

Perspective view

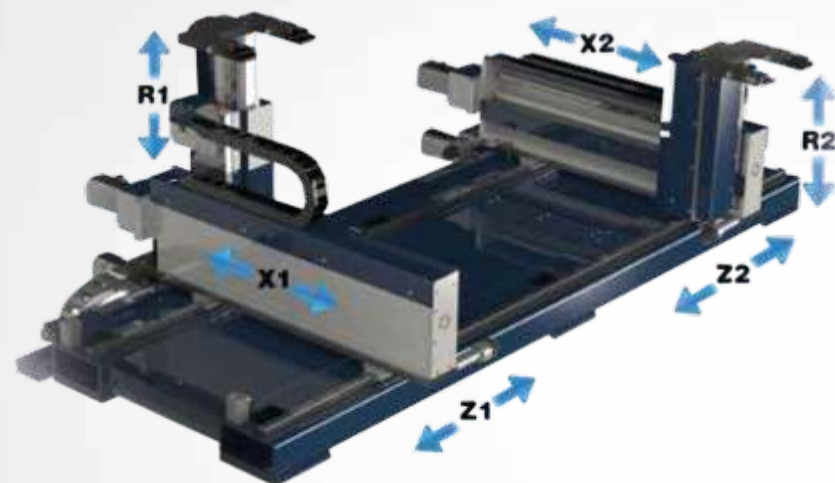

D-Series - Technical Specifications

D Bending Force	Bending Length	Distance between columns		Stroke	Daylight	Throat	Table Height	Machine Dimensions			Speed			Oil tank	Weight	Main motor
	A	B	C	J	D	E	Length x Width x Height (L x W x H)			Approach Speed	Return Speed	Bending Speed	Lt	kg	kW	
	mm	mm	mm	mm	mm	mm	mm			mm/s	mm/s	mm/s				
D100	2600	2150	410	615	510	890	4220	2230	3050	200	135	10	180	7150	7,5	
	3100	2600	410	615	510	905	4670	2230	3050	200	135	10	180	7500	7,5	
D135	3100	2600	410	615	510	935	5300	2815	3100	210	130	10	180	8950	11	
	3700	3200	410	615	510	945	5900	2815	3100	210	130	10	180	10600	11	
D175	3100	2600	410	615	510	935	5300	2775	3155	180	130	10	180	10300	15	
	3700	3200	410	615	510	945	5900	2775	3155	180	130	10	180	11950	15	
D220	4100	3600	410	615	510	945	6300	2815	3100	210	130	10	180	12650	15	
	3100	2600	410	615	510	965	5300	2795	3250	180	140	10	290	12050	18,5	
D270	3700	3200	410	615	510	965	5900	2795	3250	180	140	10	290	13600	18,5	
	4100	3600	410	615	510	965	6300	2795	3250	180	140	10	290	14600	18,5	
	5100	4200	410	615	510	995	7300	2795	3300	180	140	10	290	17600	18,5	
D320	6100	5100	410	615	510	995	8300	2795	3300	180	140	10	290	22300	18,5	
	3100	2600	410	615	510	950	5300	2765	3250	150	120	10	290	14150	22	
	3700	3200	410	615	510	955	5900	2765	3250	150	120	10	290	15350	22	
D370	4100	3600	410	615	510	955	6300	2765	3250	150	120	10	290	16350	22	
	3100	2600	410	635	510	960	5300	2755	3250	150	110	10	290	15800	22	
	3700	3200	410	635	510	960	5900	2755	3250	150	110	10	290	16600	22	
D420	4100	3600	410	635	510	1010	6300	2765	3350	150	110	10	290	17900	22	
	5100	4200	410	635	510	1025	7300	2785	3350	150	110	10	290	22600	22	
	6100	5100	410	635	510	1055	8300	2785	3350	150	110	10	290	27100	22	
D470	3100	2600	410	635	510	1015	5300	2775	3600	100	80	8	400	19800	30	
	3700	3200	410	635	510	975	5900	2775	3600	100	80	8	400	22000	30	
	4100	3600	410	635	510	975	6300	2790	3600	100	80	8	400	23850	30	
D520	5100	4200	410	635	510	975	7300	2790	3600	100	80	8	400	26650	30	
	6100	5100	410	635	510	1055	8300	2790	3730	100	80	8	400	34000	30	
	8100	7100	410	635	510	815	10150	2790	3750	100	80	8	400	46000	30	
D570	3700	3200	410	635	510	1025	5900	2730	3625	80	70	8	500	25500	37	
	4100	3600	410	635	510	1025	6300	2740	3625	80	70	8	500	27950	37	
	5100	4200	410	635	510	1055	7300	2755	3650	80	70	8	500	31500	37	
D620	6100	5100	410	635	510	965	8200	3150	3900	80	70	8	500	41000	37	
	8100	7100	410	635	510	750	10200	3200	3950	80	70	8	500	57000	37	
	4100	3200	410	675	610	995	6300	3125	4050	80	80	8,5	550	34000	45	
D670	5100	4200	410	675	610	995	7300	3260	4050	80	80	8,5	550	37000	45	
	6100	5100	410	675	610	995	8350	3260	4050	80	80	8,5	550	49000	45	
	8100	7100	410	675	610	750	10300	3250	4050	80	80	8,5	550	68000	45	
D720	4100	3200	410	675	610	750	6300	3200	4150	75	70	6	780	44000	45	
	6100	5100	410	675	610	750	8300	3250	4150	75	70	6	780	62000	45	
D770	8100	7100	410	675	610	750	10500	3250	4150	75	70	6	780	87000	45	
	4100	3200	510	775	610	750	6400	3650	4150	70	65	6	1000	70000	45	
D820	6100	5100	510	775	610	750	8400	3650	4350	70	65	6	1000	76000	45	
	8100	7100	510	775	610	750	10500	3650	4750	70	65	6	1000	105000	45	
D870	6100	5000	510	775	610	750	8500	3650	4850	70	55	6	1000	92000	55	
	8100	7100	510	775	610	750	10600	3650	4850	70	55	6	1000	130000	55	
D920	6100	5000	510	775	610	750	8600	3900	4950	70	55	6	1300	111000	75	
	8100	6500	510	775	610	750	10700	3900	4950	70	55	6	1300	153000	75	
D970	6100	4500	510	775	610	750	8600	4050	5050	70	60	5	1700	152000	90	
	8100	6500	510	775	610	750	10700	4050	5050	70	60	5	1700	210000	90	

*For dimension details please look at left page.
**Technical specifications may change without advance notice.

BACK GAUGE OPTIONS

- 0,03mm accuracy,
- High speed,
- Strong structure,
- Linear scales,
- Ball bearing system without backlash,
- 3 step fingers with micrometric adjustment,
- Robust design againts hard impacts

X AXIS BACK GAUGE



A Series **B Series** **C Series** **D Series**

A Series High accuracy A/C inverter motor back gauge
B Series High accuracy MITSUBISHI SERVO Motor
 X travel 750mm

X+R AXES BACK GAUGE



A Series **B Series** **C Series** **D Series**

X travel 750mm, R travel 250mm
 Linear guided strenghtened R axis

X, R, Z1, Z2 AXES BACK GAUGE



A Series **B Series** **C Series** **D Series**

X travel 750mm, R travel 250mm
 Z1,Z2 travel along the back gauge bar

X, R, Z1, Z2 +X5 AXES BACK GAUGE



A Series **B Series** **C Series** **D Series**

X travel 750mm, R travel 250mm, X5 travel 200mm (+-100mm)
 Z1,Z2 travel along the back gauge bar

X1, X2, R1, R2, Z2 ATF BACK GAUGE



A Series **B Series** **C Series** **D Series**

6 Axes tower type
 Robust design against impacts

SAFETY OPTIONS

LeMans

**AKAS FPSC
FRONT LASER SAFETY**



A Series B Series C Series D Series

**MSD
FRONT LASER SAFETY**



A Series B Series C Series D Series

**DSP
FRONT LASER SAFETY**



A Series B Series C Series D Series

**FRONT
LIGHT BARRIER**



A Series B Series C Series D Series

**AKAS II
FRONT LASER SAFETY**



A Series B Series C Series D Series

**AKAS III - MOTORIZED
FRONT LASER SAFETY**



A Series B Series C Series D Series

**REAR SAFETY
LIGHT BARRIER**



A Series B Series C Series D Series

**REAR SAFETY
LIGHT BEAMS**

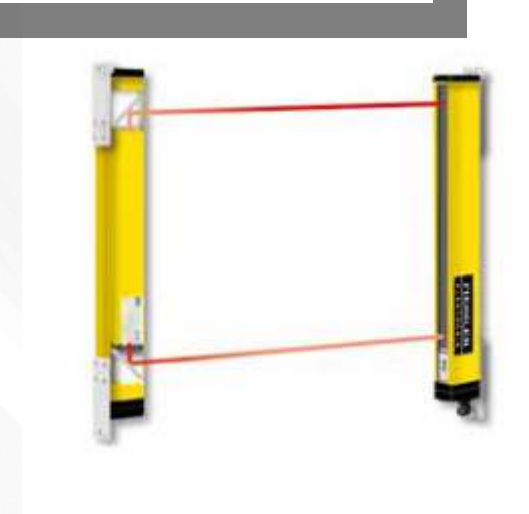

A Series B Series C Series D Series

TOP TOOL CLAMPINGS

- Easy tool changing
- Fast
- Vertical tool changing
- Safe tool changing
- Options for different needs
- Strong and durable

WILA NSCL
HYDRAULIC PUNCH CLAMPING



A Series B Series C Series D Series

ROLLERI ROL 200
HYDRAULIC PUNCH CLAMPING



A Series B Series C Series D Series

MANUAL
PROMECAM CLAMPING



A Series B Series C Series D Series

MANUAL QUICK
CLAMPING PROMECAM



A Series B Series C Series D Series

TEDA / EUROSTAMP
PNEUMATIC PUNCH CLAMPING



A Series B Series C Series D Series

T - CHANNEL
PUNCH CLAMPING



A Series B Series C Series D Series

CROWNING & BOTTOM TOOL CLAMPINGS

EUROPEAN TYPE
DIE HOLDER



A Series B Series C Series D Series
60mm or 90mm European type die holder

WIDE TYPE
BOTTOM TABLE



A Series B Series C Series D Series
150mm, 240mm, 320mm, ...

MANUAL
CROWNING



A Series B Series C Series D Series

MOTORISED
CROWNING



A Series B Series C Series D Series

WILA NSCR
HYDRAULIC DIE HOLDER



A Series B Series C Series D Series

WILA / AMERICAN
MANUAL DIE HOLDER



A Series B Series C Series D Series

OTHER OPTIONS

LASER CHECK
AUTO ANGLE MEASUREMENT SYSTEM

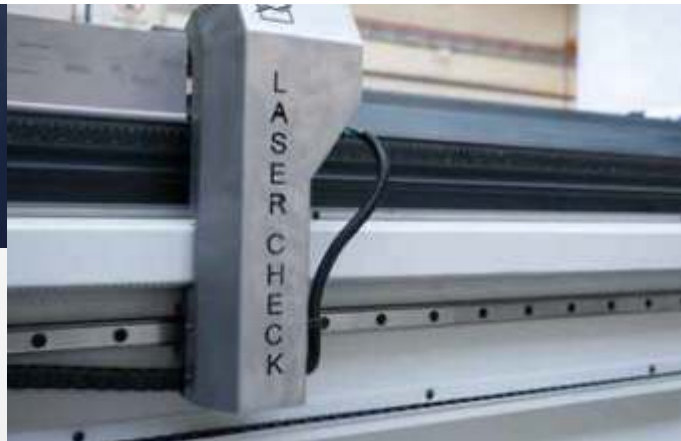

A Series B Series C Series D Series

AP01 / AP02
FRONT SHEET FOLLOWER ARMS



A Series B Series C Series D Series

MITUTOYO
ANGLE MEASUREMENT DEVICE



A Series B Series C Series D Series

CABIN COOLER
AC COOLING SYSTEM



A Series B Series C Series D Series

MANUAL / AUTOMATIC
SLIDWAY LUBRICATION



A Series B Series C Series D Series

OIL
COOLER / HEATER



A Series B Series C Series D Series

PNEUMATIC
THIN SHEET SUPPORT ARMS



A Series B Series C Series D Series

BIG
THROAT



A Series B Series C Series D Series

500mm to 1.500mm

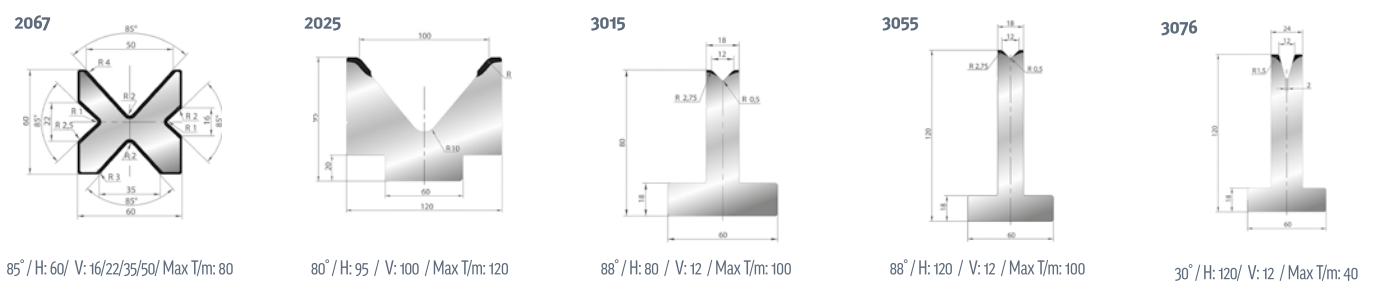
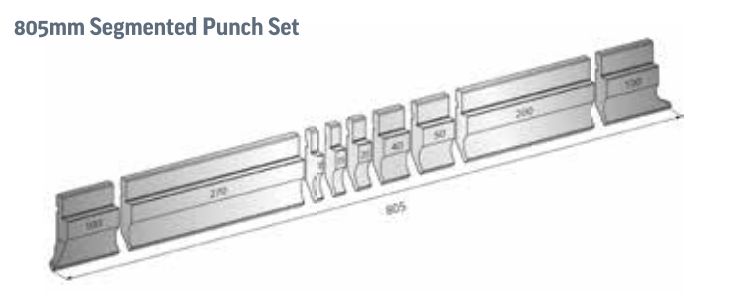
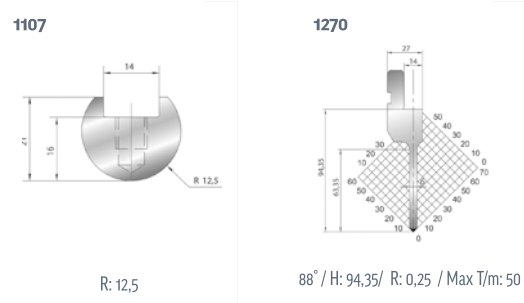
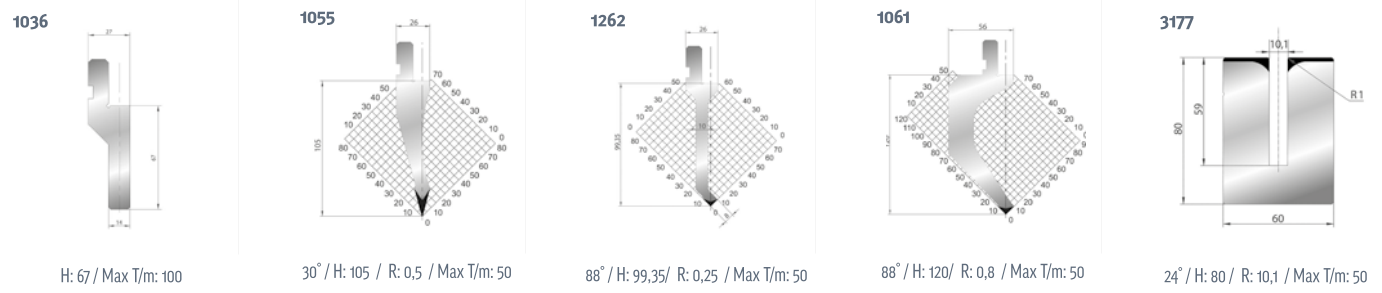
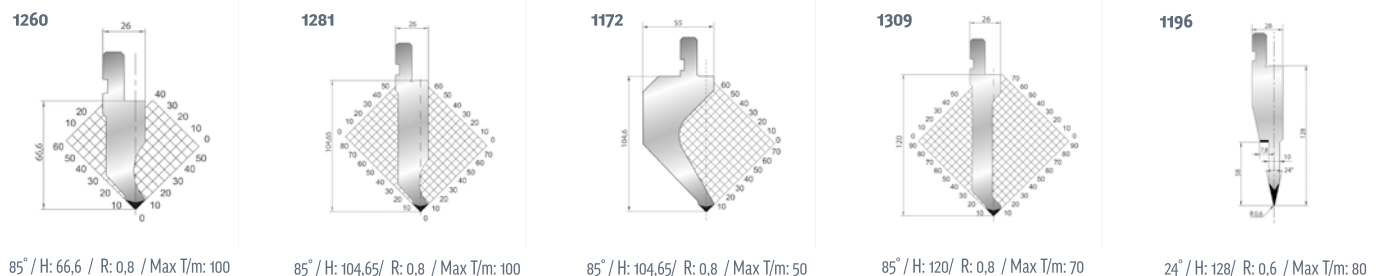

Multi Vee Dies (Wide Table)

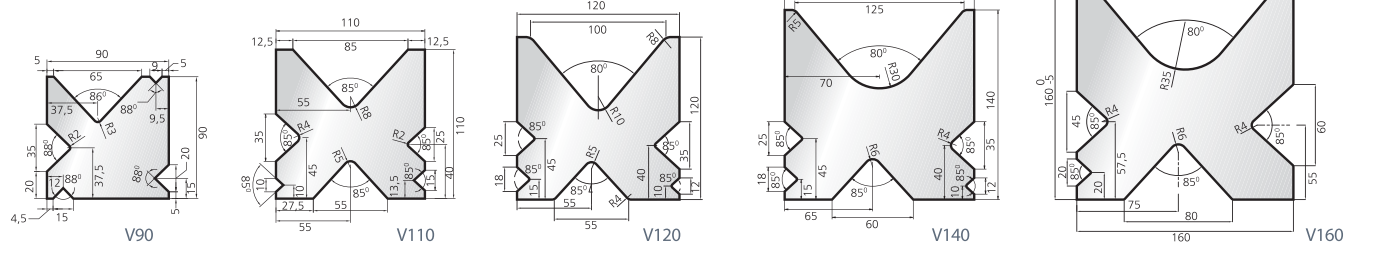

805mm Segmented Die Set



VLM- Adjustable Die

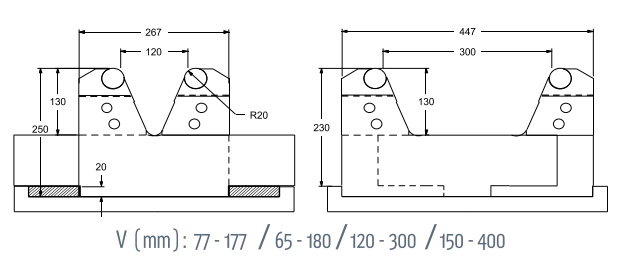

Bending Chart

V	R	B	0,5	0,8	1	1,2	1,5	2	2,5	3	4	5	6	8	10	12	15	20	25	30
4	0,7	26	4	10,5																
6	0,9	3,9	2,6	6,9	10,6	15,3														
8	1,5	5,2	2	5,5	8	11,5	18													
10	1,7	6,5		4,1	6,5	9,5	14,5	26												
12	2	7,8			5,5	8	12	21,5	33,5											
16	2,7	10,4				6	9	16	25	36										
20	3,4	13					7,5	13	20	29	52									
24	3,9	15,6						10,6	17	24	43	67								
30	5	20							14	19	34	54	77							
35	6	23								17	30	46	66							
40	7	26								15	26	40	58	103						
50	8,5	32									21	32	46	82	120					
55	9	36										30	42	75	117					
60	10	39										27	39	69	107					
70	11,7	45											33	59	92	132				
80	13,5	52											29	52	80	116	180			
90	15	58												46	71	103	160			
100	17	65												41	64	93	144			
120	20	78													54	77	120			
140	24	91														66	103	183		
160	25	104															90	160	250	
200	31	130															72	128	200	
250	39	163																102	160	230
300	47	195																85	133	192

$$F = \frac{S^2 \times 2 \times TS}{1.4 \times V} = \dots \text{ ton/m}$$

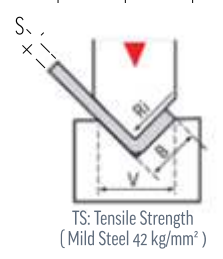

PUNCH Holders

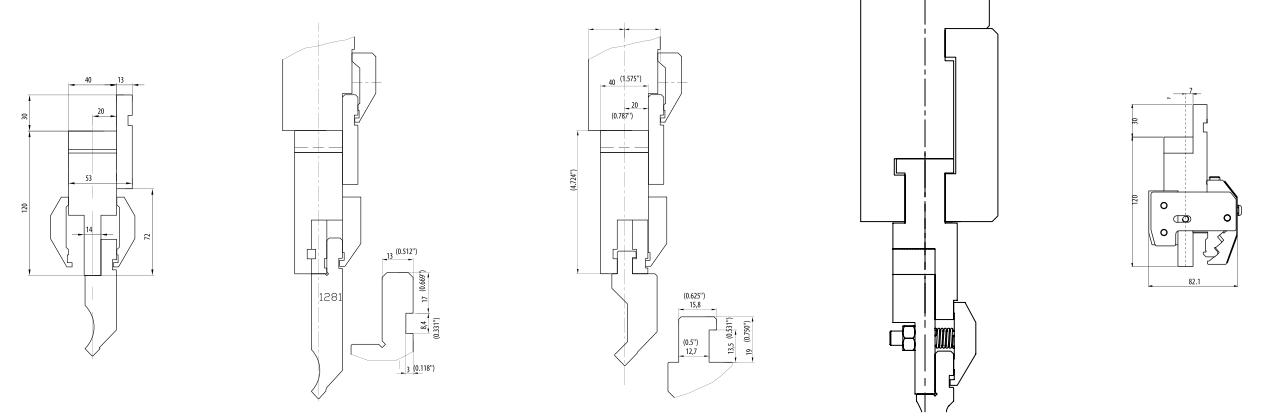

DIE Holders

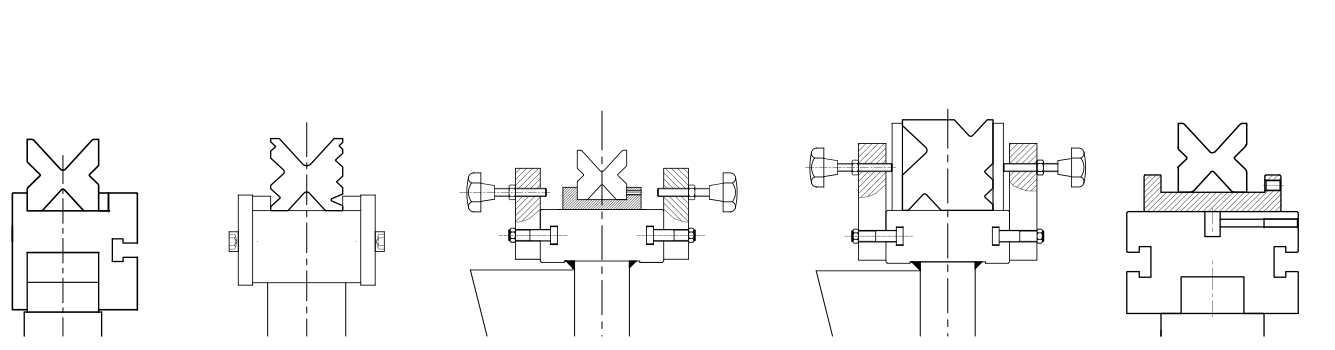



www.lemans-cnc.cz

LeMans